









QTS-75-HP3

FOR ALUMINIUM AND STEEL HULLS

- * The **QTS-75** underwater light insert uses a high impact **borosilicate glass** lens (Test Pressure 100 bar). The beam angle is 120 degrees.
- * Never feel trapped by this fixture. The **LED BALL** has universal adjustment. The **LED BALL** is designed to accept white, Blue and RGB+W configurations and can be easily removed for servicing without the hassle of hauling your boat.
- * The **QTS-75** power supply to the driver is 110-240 vac
- * The **QTS-75** has Lloyd's Register Approval and ABS Design Appraisal.
- * The **QTS-75** is suitable for welding into steel and aluminium hulls using our 3 types of inserts which have been machined so they can be welded flush to the hull plating at appropriate positions.

-  **Maintenance**
Inside the Hull
-  **Control**
DALI & On/Off
-  **Driver**
Remote
-  **Lens and Pressure Test**
Borosilicate Glass- 100 bar
-  **Power**
110-240 VAC
-  **Installation**
Weld-in





QTS-75

underwater lights ltd

QtLED

REVERSE BEFORE LIGHTING

IPX8

- Hull Material** 
Aluminium / Steel
- Boat Size** 
30 meter +
- Lumens** 
20,000
- Kelvin** 
6,500
- Beam Angle** 
120 Deg

IPX8
Underwater



www.underwaterlights.com

THE QT-LED RANGE IS DESIGNED AND MANUFACTURED BY UNDERWATER LIGHTS LTD IN THE U.K.

Type-QTS-75-HP Issue 'A', Date-4.4.22



QTS-75-HP3

Mounting

Hull Material	Aluminium & Steel
Boat size	30 meters to 200 meters
Spacing	1.5- 2.5meters for Transom & 2.5 to 6meters for P & S)
Beam Angle	120°
Installation Angles	Flush to shell plating

Physical

Lengths and diameters see opposite	
Removal Space Required	100mm 4"
Total weight	SS: 10 - 12.7kg (21 - 28lbs) ALU: 8.2-9.1kg (18 - 20lbs)
Driver Dimensions (L x W x H)	9" x 4.9" x 3.5" (220 x 120 x 90mm)
Cable Lengths	3meters (13ft) to 24 meters
Material-Weld in	5083 Aluminium / 316L Stainless Steel
Glass Lens	Borosilicate Glass Lens

Material and Part numbers for WHITE and BLUE						
Material	Diameter 120 mm		Diameter 140 mm			
316L S.S.	QTS-75-3120-W	QTS-75-3120-B	QTS-75-3140-W	QTS-75-3140-B	QTS-75-3145-W	QTS-75-3145-B
5083 ALU	QTS-75-6120-W	QTS-75-6120-B	QTS-75-6140-W	QTS-75-6140-B	QTS-75-6145-W	QTS-75-6145-B

Technical

Lumens	20,000 Lumens for white
Kelvin	6500
Typical LED Life Expectancy	40,000 hrs
Min-Max Operating Voltage	110 - 240V AC
Current /Amp draw	1.4A - 0.7A
Driver Type	External
Driver Output	54vdc-2.8A
Driver wattage	144 WATTS
Control Option	Dali & ON/OFF
Bonding	Welded
EMF Earth Leakage	0.27mA / 19.5mV

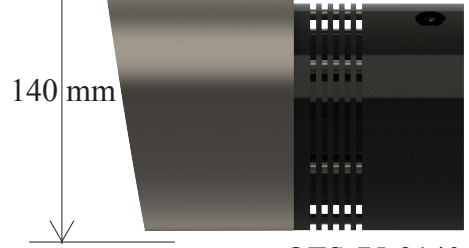
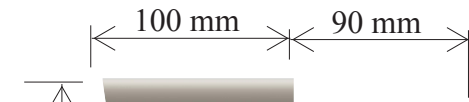
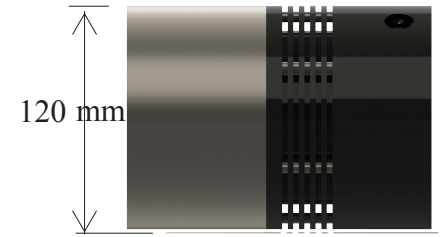
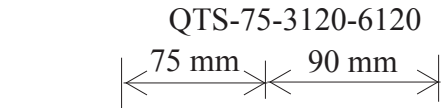

QTS-75-3140-6140

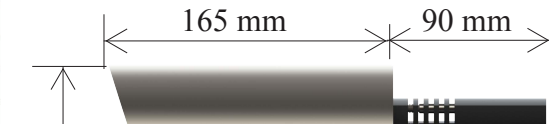

QTS-75-3145-6145

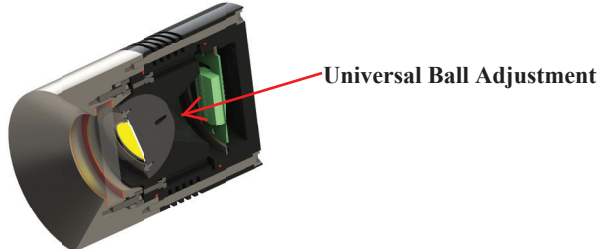

Your Local Dealer

© 2019 Underwater Lights Limited All Rights Reserved.
Underwater lights limited reserves the right to change specifications without notice.

The Great Dunton Forge, London Road
Dunton Green, Sevenoaks, Kent TN13 2TD UK
T: +44 (0) 1732 455753 • F: +44 (0) 1732 743233
E: uwl@underwaterlights.com

www.underwaterlights.com

VAT NO: 556 4425 31 Registered in England No: 2348038

QtLED QTS-75



Installation information

***DESCRIPTION** - The QTS-75 range is a submersible through hull marine light with a universal 25 degree ball adjustment. There are two types of insert which have been machined so they can be welded flush to the hull plating at the appropriate locations. Final adjustment of the beam angle to the horizontal is carried out from inside the hull. See instructional information below

***LENS FITTING INSTRUCTIONS**-Remove the blanking plate and check the insert (1) lens landing surfaces are clean and apply a suitable silicone grease to the gaskets (2). Fit the lens (3), gaskets(2) and lens retaining ring (4) . Hand tighten the cap head bolts (6) and spring washer (5)making sure the lens retaining ring (4) is square. Torque the bolts to 7 Nm (4.5ft/lbs) in the sequence shown opposite, check the ring again and re-torque the screws again to the same setting.

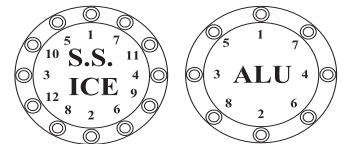

*** LED PROJECTOR FITTING INSTRUCTIONS**-The LED heat sink (8) with the 'O'ring (7) fitted is inserted into the insert (1) and secured with bolts(10). The LED ball can then be adjusted. The cover (9) with the 'O' ring fitted is inserted to the LED heat sink (8) and bolted up using bolts (11) securing all parts to the insert (1). Torque these bolts to 7Nm (4.5ft/lbs)

DESCRIPTION	Qty
1-INSERT S.S	1
1-INSERT ALU	1
2-GASKET	2
3-GLASS LEN	1
4-LENS SECURING RING S.S	1
4-LENS SECURING RING ALU	1
5-M6 SPRING WASHERS S.S	12
5-M6 SPRING WASHERS	NA
6-M6 CAPHEAD BOLTS A4	12
6-M6 CAPHEAD BOLTS TI	8
7-'O' RING	3
8-LED HEATSINK	1
9-LED HEATSINK COVER	1
10-M6 TITANIUM CAPHEAD BOLTS	6
11-M6 TITANIUM CAPHEAD BOLTS	3

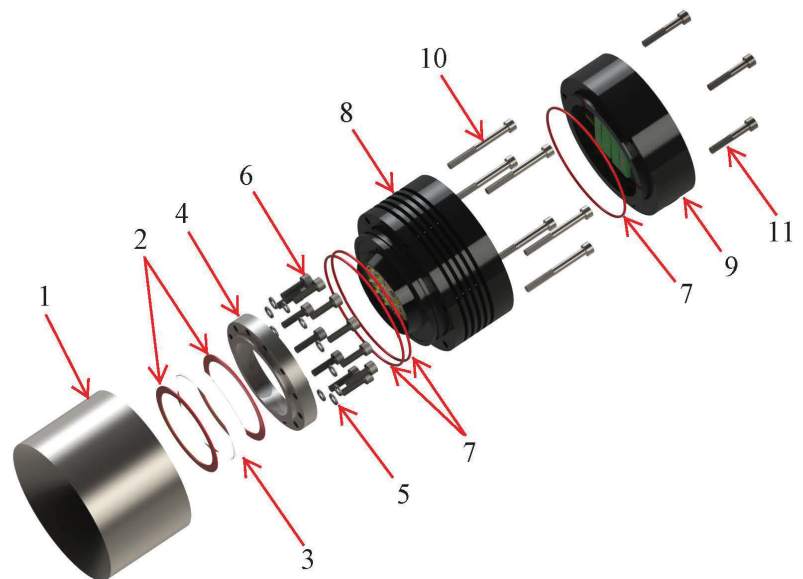

QtLED QTS-75 INSERT SELECTION

- *The QTS-75 insert range of underwater lights are a dedicated LED light unlike the QT-75 insert range that can be used for metal halide (HQI) or LED.
 - *There are three types of QTS-75 inserts that are machined and can be cut ready for immediate welding into the hull shell plating without worrying about insert angles only the **orientation** of the insert relative to the plate angle.
 - *There are two orientations of the insert 'A' and 'B' which relate to the hull plate angle relative to the horizontal. This is explained below.
 - *For plate angles 69 - 90 degrees the orientation is (B) and below 69 degrees the orientation is (A)
 - *The light beam is simply adjusted by a universal ball mechanism inside the LED projector. This is done from inside the hull to get the correct beam angles of around 20 - 30 degrees
 - *The diagram below has the beam angle adjusted to 20 degrees down relative to the horizontal and the inserts are welded to the shell plate as shown below.
- Note the insert orientation. The beam can also be adjusted left or right.

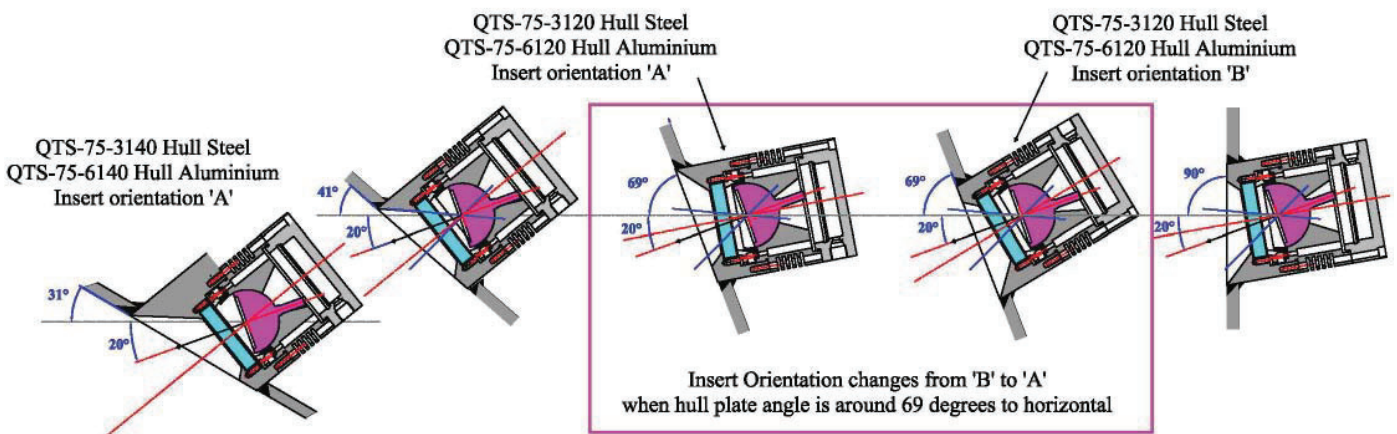

QT LED an Underwater Lights Ltd. Company
The Great Dunton Forge, London Rd, Dunton Green,
Suttonia, Kent TN13 2TD TEL: +44 1732 453753
Web: www.QtLED.COM EMAIL: INFO@QtLED.COM

TITLE
QTS-75 INSTALLATION

LIGHT INSERTS BELOW ARE FOR WHITE, BLUE AND RGB+W LEDS
ALLOW 8CM AT REAR OF LIGHT FOR MAINTENANCE
THE LED BALL HAS A 30 DEGREE UNIVERSAL ADJUSTMENT.
SEEN ON THE DRAWINGS ARE BLUE LINES WHICH HAVE AN
ANGLE OF 25 DEGREES TO THE CENTER LINE. SO THERE IS A
PLATE ANGLE TOLLERANCE OF 5 DEGREES AND THE LED BALL
CAN BE ADJUSTED FOR A DOWNWARD ANGLE OF 20-30 DEGREES

*The LINES PLAN below shows the curvature of the hull transverse frames and the blue horizontal lines indicate the draft where the inserts are located at a minimum of 300mm below the vessels draft with 50% water and fuel.

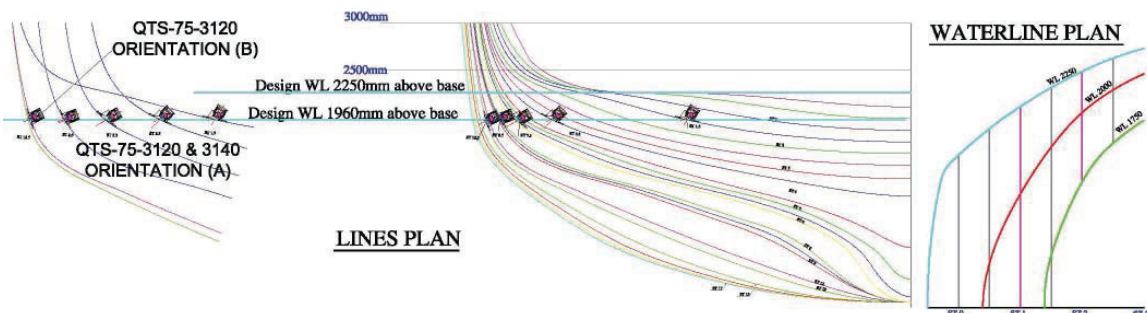
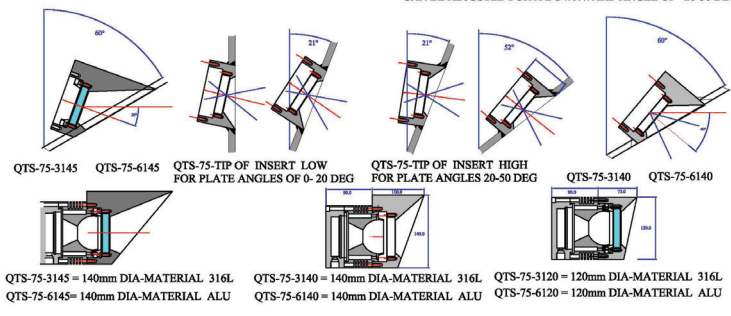

For sales telephone numbers visit www.underwaterlights.com
THE QT-LED RANGE IS DESIGNED AND MANUFACTURED BY UNDERWATER LIGHTS LTD IN THE U.K.

The inserts are delivered fully protected with cover and blank disc which **must not be removed** during welding and painting.

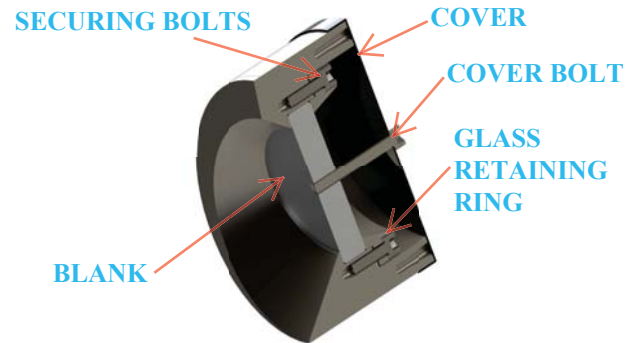

The 75 range welding procedures shown are typical for most installations and are for guidance pur-poses only. Always use a certified welder and a fire watch when welding. Protect all threads and internal surfaces against welding, grinding and painting.

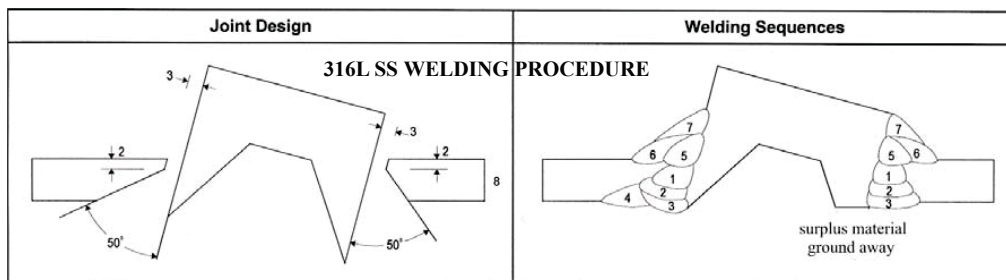

RUN	PROCESS	SIZE OF FILLER METAL	CURRENT A	VOLTAGE V	TYPE OF CURRENT/POLARITY	WIRE FEED m/min	TRAVEL SPEED* mm/s	HEAT INPUT* kJ/mm
1-7	MMA	3.2	100-115	≥ 55 OCV	AC	-	-	-

Welding procedure Ref.No: UL-CSSS-TB-01	Welding position: Butt: Horizontal (PC) and vertical up (PF)
Joint type: Full penetration butt with fillet	Fillet: Overhead (PD), vertical up (PF) and horizontal vertical (PB)
Preparation & cleaning: Thermal cut and grind	Gas flux shielding: Acid rutile flux
Parent material spec: ASTM A276:316L stainless to BS 4360:43A carbon steel	Details of back gouging: Back grind root of butt
Material thickness (mm): 4-20 (Bulleyt) to 8mm plate	Preheat temperature: 10°C min.
Outside diameter (mm): 100mm	Interpass temperature: 240°C max.
Filler metal classification: AWS A5.4:E309MOL-17	Temperature control: Thermal indicating crayon
Filler metal tradename: ESAB OK 67.70	

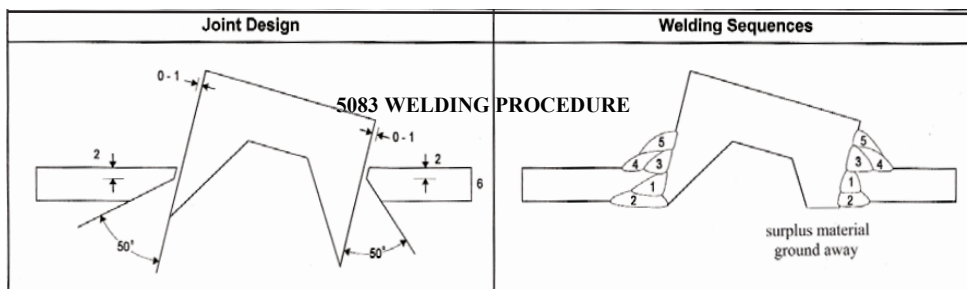

RUN	PROCESS	SIZE OF FILLER METAL	CURRENT A	VOLTAGE V	TYPE OF CURRENT/POLARITY	WIRE FEED m/min	TRAVEL SPEED* mm/s	HEAT INPUT* kJ/mm
1-5	MIG	1.2	160 - 180	20 - 21	DC positive	± 10.0	10 - 15	-

Welding procedure Ref.No: UL-AL-TB-01	Welding position: Butt: Horizontal (PC) and vertical up (PF)
Joint type: Full penetration butt with fillet	Fillet: Overhead (PD), vertical up (PF) and horizontal vertical (PB)
Preparation & cleaning: Cut, grind, wirebrush & degrease	Gas flux shielding: Argon gas
Parent material spec: BS 1474:5083:0 (Bulleyt) to BS 1470:5083:0 (plate)	Gas flow rate - shielding: 20 LPM
Material thickness (mm): 4-20 (Bulleyt) to 6mm plate	Details of back gouging: Back grind root of butt
Outside diameter (mm): 100mm	Preheat temperature: 10°C min.
Filler metal classification: BS 2901:pt 4:5356	
Filler metal tradename: INCO ALLOYS 5356	