

# QtLED QTS-100 White & Blue

- \*The **QTS-100** underwater light fixture uses a high impact borosilicate glass with a flat lens for a 140 degree wide beam angle. The fixture also allows for an increase in Led power for extra light output.
- \*Never feel trapped by this fixture as the LED projector is designed for White and Blue or RGB+W and can be easily removed for servicing and upgrades without the hassle of hauling your boat.
- \*The cool white LED has a minimum output of 10,000 lumens. With its 140 degree beam angle, the flush fixture provides a perfect illumination.
- \*The **QTS-100** is recommended for GRP, Carbon Fibre and Wooden hull yachts of 20m +.
- \*Distance between lights on the transom can vary from 1 to 1.5m and from 1 to 3m for port and Starboard.
- \*The **QTS- 100** has Lloyd's Register Approval and ABS Design Appraisal on all components. Using the latest technology allows our underwater lights to perform well in the harshest environment.
- \*The **QTS- 100** is made from anodized aluminium and titanium.

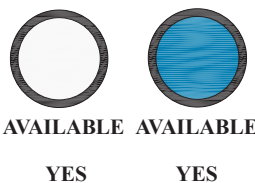
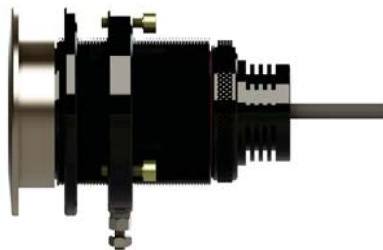

- Maintenance**  
Inside the hull
- Control Option**  
On/Off Switched
- Driver**  
Integral
- Growth Resistant Lens**  
Borosilicate Glass-
- Power**  
12-24 vdc
- Installation**  
Thru Hull

- Hull Material**  
GRP/Carbon Fibre
- Boat Size**  
20m+
- Lumens**  
10,000
- Kelvin**  
6,500K
- Beam Angle**  
140 Deg

**IPX8**  
Underwater

Front of Light only

[www.underwaterlights.com](http://www.underwaterlights.com)

THE QT-LED RANGE IS DESIGNED AND MANUFACTURED BY UNDERWATER LIGHTS LTD IN THE U.K.





# QTS-100

## Thru-Hull - Led serviced From inside

### Mounting

Hull Material	GRP / Fiberglass/Carbon Fibre
Boat size	20meters+ (65ft+)
Spacing	1-1.5M /1-3M port & Starboard
Beam Angle	140°
Installation Angles	Flush

### Technical

Lumens	10,000 for the white LED
Kelvin	6,500
Typical LED Life Expectancy	40,000 hrs
Min-Max Operating Voltage	11-28 V DC
Current / Amp draw	7-3.5 amp
Driver Type	Integral
Driver Output	55VDC-1.4A
Control Options	On / Off Switch
Bonding	Locking Ring

### Physical

Length of fixture	140mm (5.5")
Diameter of fixture	100 mm (4")
Profile (height) of fixture	11 mm (7/16")
Removal Space Required	170 mm (6 11/16")
Total weight	1.7KG (3.74lbs)
DMX Driver Dimensions (L x W x H)	N.A
Cable Length	2 meters (6.5ft)
Hole Cut-out	74mm (2.91")
Material	Titanium and anodised aluminium
Growth Resistant Lens	Borosilicate Glass
Maximum Hull Thickness	80mm (3 1/4")

### Color

White



Blue



### Part Number

QTS-100-W-LP-V5/6-Ti

QTS-100-BLUE-V5/6-Ti

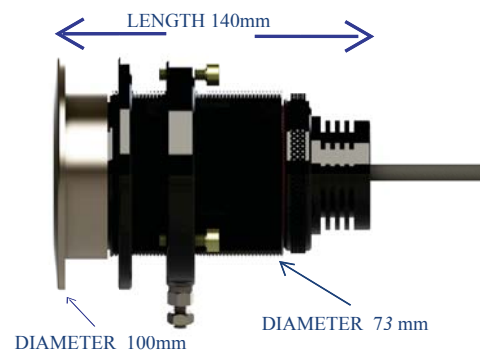

Your Local Dealer



© 2017 Underwater Lights Limited All Rights Reserved.  
Underwater lights limited reserves the right to change specifications without notice.

The Great Dunton Forge, London Road  
Dunton Green, Sevenoaks, Kent TN13 2TD UK  
T: +44 (0) 1732 455753 @F: +44 (0) 1732 743233  
E: uwl@underwaterlights.com

[www.underwaterlights.com](http://www.underwaterlights.com)

VAT NO: 556 4425 31

Registered in England No: 2348038

# QtLED QTS-100 Install

**\*QTS LED 100 Installation (Maximum hull thickness 80mm) and Operation instructions.**

The QTS 100 RGB+W is a “through- hull” submersible marine light using and is delivered ready for installation. Maintenance of the LED is carried out from inside the hull. The light is suitable for installation into GRP-fiberglass and wooden hulls. The led is driven by an external 24vdc driver ( 4 channels @72vdc) or a mains Driver 110/240 vac.

**\*Qualified/Approved personnel must be used to carry out installation**

Before cutting a 74mm hole in the hull, check the hull wall thickness is not greater than 80mm. The location of the holes must be below the waterline. After finishing the hole surface, check the Body (1) can be inserted.

**\*Note for cored hulls** - After cutting, the exposed surfaces of the hole must be finished to form a solid surface through it. Thus protecting the internal core of the hull. The wall thickness of the hole should not to less than 5mm-0.25inch. Apply 3M-4200FC sealant to the ‘Body’ (1) flange. Slide the body into the hole and from inside the hull put the ‘compensating ring’ (3) on and screw the securing ring’ (4) up hand tight. Gently tighten the adjustment screws (7) so the compensating ring is flush to the hull and the sealant has flowed completely around the flange and hull.

**\*Do NOT overtighten the bolts** as this will squeeze the sealant from the surfaces. Allow the sealant to solidify and remove surplus. Finally tighten the bolts (5) to 4Nm. / 3ft. lbs.

\*It is not necessary to remove the heat sink parts (2, 5 & 7) when carrying out installation.

\* To remove the heat sink (2) unscrew the clamp ring (5).

\*Before fitting the new LED heat sink (2) ensure the barrel part of the body (1) and the lens is clean. Use silicone spray to lightly coat the heat sink (2), clamp ring (5) and sealing ‘O’ rings (6). Slide the heat sink (2) into the barrel and tighten the knurled securing clamp ring (5) to secure the heat sink (2) into the body. When the heat sink (2) cannot be rotated the clamp ring (5) has secured all in place. If this is not done it will cause overheating of the LED and the LED could fail.

**\*Caution:** do not operate lights unless totally submerged. Maximum cable length should not exceed 6m due to voltage drops. After completing the installation procedure it is highly recommended to coat the BODY (1) face with antifouling and bond the lights to the anodes or a cathodic protection system as shown below.

\*EARTHING LIGHT FOR CATHODIC PROTECTION-tighten the earth screw (8) on the securing ring (4) so that it bites into the screwed barrel. Then connect your bonding cable to the earth screw and use the nut to hold this in place. Check there is continuity to the front face. This prevents galvanic corrosion.

\*ALL EXISITING WIRING, BREAKERS & FUSES MUST BE CHECKED BEFORE UPGRADING BY A REPUTABLE INSTALLER OR SURVEYOR

\*The light must be installed onto a flat (not curved) surface. Mount on transom or side hull only.

\*The light is supplied with the LED heatsink (2) done up tight. You must check this is still done up hand tight with the clamp ring (5) after install whether you remove the insert or not

QTS 100 Description	Qty.
1; BODY	1
2; LED HEAT SINK	1
3; COMPENSATING RING	1
4; SECURING RING	1
5; CLAMP RING	1
6; 'O' RINGS	2
7; ADJUSTMENT SCREWS	3
8; EARTH SCREW	1

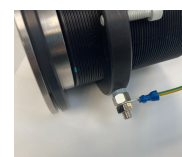
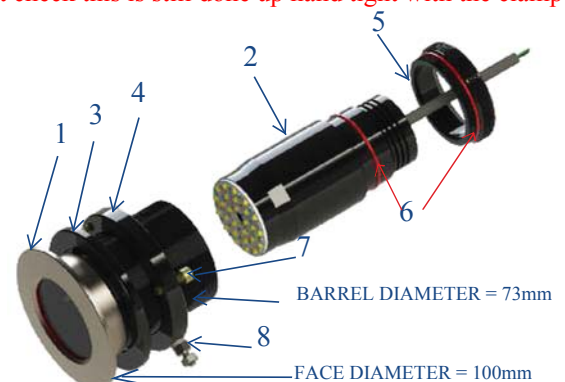

ITEM 8

EARTH SCREW

**TECHNICAL SPECIFICATION**

- \*Supply Voltage 110-240vac. Maximum 150w-current 1.3-0.7
- \*LED Driver Remote
- \*BODY Materials Titanium & 5083 ALU.



# DC POWER CONNECTIONS

POWER AND CONNECTION INFORMATION FOR -  
QT-80-Ti, QTS-100, QTS-100 DUAL, AND QTS-100-RGB+W

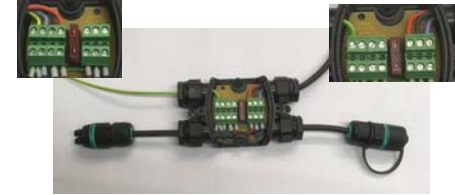
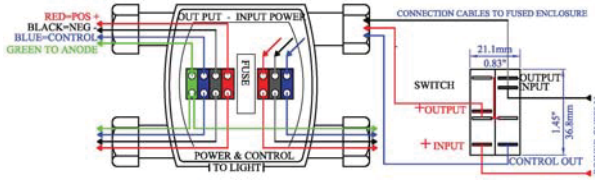

BLUE CONNECTIONS FOR DUAL LIGHTS ONLY DO NOT USE THE BLUE FOR SINGLE COLOUR OR RGB+W LIGHTS

TWO WAY FUSED ENCLOSURE POWER FROM EITHER SIDE - EARTH CONNECTED TO ANODE

FOUR WAY FUSED AND SURGED PROTECTED PLUG AND PLAY ENCLOSURE

- \*The picture opposite shows a very important procedure in checking that the light is connected to the insert.
- \*Using an ohm meter connect the light bezel to the anode. The ohm value should be less than 1 ohm.

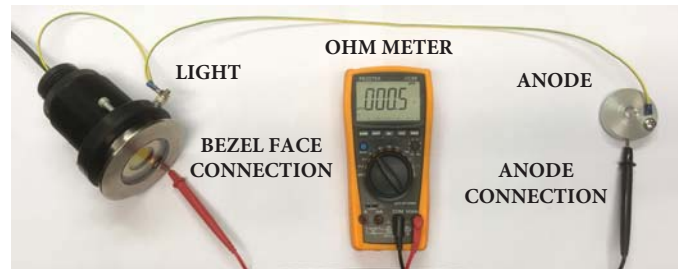

\*The four way fused/surged protected and the two way fused only enclosure protects the power cable to the lights only. The lights are supplied with cable and plug for easy connection. The earth cable has to be connected to the anode. **You are responsible to fuse the power supply cable.**

\*Lights supplied with no plug will require connection inside the two way connector as shown in the diagram above.

\*The table below shows the lumen, power, current draw for each light at 12 and 24 volts and the fuse rating for each light when not using our enclosures It also shows the supply amperage for each enclosure with the maximum amount of lights connected.

\* We do not supply the input power cable. Please use the cable size list to select the correct cable. This supply cable must be fused for protection and the recommended **SUPPLY CABLE FUSE** is in the list below.

MODEL NUMBER	LUMEN OUTPUT	11 VDC SUPPLY POWER, DRAW CURRENT & FUSE RATING	24 VDC SUPPLY POWER, DRAW CURRENT & FUSE RATING	TWO WAY ENCLOSURE WITH TWO LIGHTS DRAW AMPS 12 - 24VDC - SUPPLY CABLE FUSE	FOUR WAY ENCLOSURE WITH FOUR LIGHTS DRAW AMPS 12 - 24VDC - SUPPLY CABLE FUSE
QT-80-Ti-40	7,000	40 WATTS - 4.0 AMPS - 10 AMP	40 WATTS - 2.0 AMPS - 10 AMP	8.0 A - 4.0 AMPS - 10 AMP	16.0 AMP - 8.0 AMPS - 20 AMP
QT-80-Ti-20	3,500	20 WATTS - 2.0 AMPS - 10 AMP	20 WATTS - 1.0 AMPS - 10 AMP	4.0 A - 2.0 AMPS - 10 AMP	8.0 AMP - 4.0 AMPS - 20 AMP
QTS-100	14,000	N/A	96 WATTS - 4 AMPS - 10 AMP	N/A - 8.0 AMPS - 10 AMP	N/A - 16.0 AMPS - 20 AMP
QTS-100 RGB+W	ALL ON	N.A	144 WATTS - 6 AMPS - 10 AMP	N/A -	24VDC - 24 AMPS - 30 AMP

Standard and Metric Wire Comparison Table	CIRCUIT TYPE				CURRENT FLOW IN AMPS											
	10% VOLTAGE DROP Non Critical		3% VOLTAGE DROP Critical		5A	10A	15A	20A	25A	30A	40A	50A	60A	70A	80A	
	0 to 20 ft.	0 to 6.1 M	0 to 6 ft.	0 to 1.8 M												
Available Wire Size AWG	16	14	12	10	8	6	4	2	0	0	0	0	0	0	0	
Available Wire Size Metric	1.5	2.5	4	6	10	16	25	40	63	100	160	250	400	630	1000	
LENGTH	30 ft.	9.1 M	10 ft.	3.0 M	16 AWG	14 AWG	12 AWG	10 AWG	8 AWG	6 AWG	4 AWG	2 AWG	0 AWG	0 AWG	0 AWG	
	50 ft.	15.2 M	15 ft.	4.6 M	14 AWG	12 AWG	10 AWG	8 AWG	6 AWG	4 AWG	2 AWG	0 AWG	0 AWG	0 AWG	0 AWG	
	65 ft.	19.8 M	20 ft.	6.1 M	14 AWG	10 AWG	8 AWG	6 AWG	4 AWG	2 AWG	0 AWG	0 AWG	0 AWG	0 AWG	0 AWG	
	80 ft.	24.4 M	25 ft.	7.6 M	12 AWG	10 AWG	8 AWG	6 AWG	4 AWG	2 AWG	0 AWG	0 AWG	0 AWG	0 AWG	0 AWG	
	100 ft.	30.5 M	30 ft.	9.1 M	10 AWG	8 AWG	6 AWG	4 AWG	2 AWG	0 AWG	0 AWG	0 AWG	0 AWG	0 AWG	0 AWG	
	130 ft.	39.6 M	40 ft.	12.2 M	8 AWG	6 AWG	4 AWG	2 AWG	0 AWG	0 AWG	0 AWG	0 AWG	0 AWG	0 AWG	0 AWG	

\* If a second Hub is requested for installing more lights, please make sure you are using the correct cable suitable for the Amps drawn